



FLANGE PER DIAFRAMMI DI MISURA

ORIFICE FLANGES

CLASSE/CLASS

300

ANSI B 16.36

DA SALDARE A SOVRAPPOSIZIONE

SLIP-ON

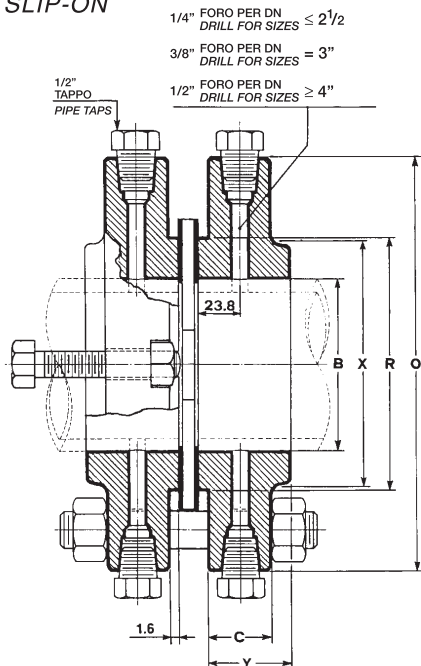

FILETTATE - THREADED

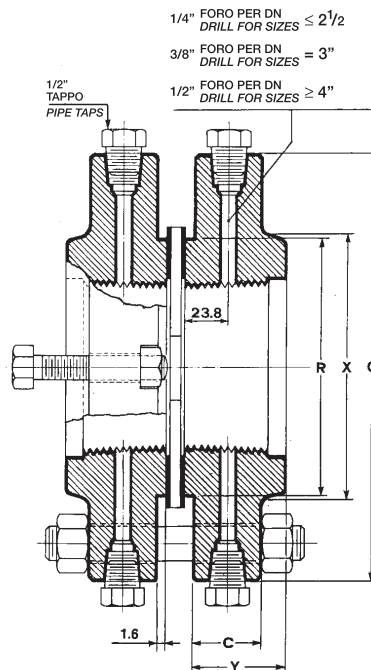

DIMENSIONS IN MM.

| DN | P | ANELLO RING N. | PROFONDITA DELLA CAVA PER BULLONI DISTANZIATORI DEPTH OF JACK | DIAM. BULLONI DISTANZIATORI JACK SCREW SIZE | FORATURA - DRILLING | | | | LUNGHEZZA TIRANTI LENGTH OF BOLTS | |
|--------|-------|----------------------|--|---|---|---------------------|---------------------|-------------------|--------------------------------------|-----|
| | | | | | DIAMETRO CERCHIO FORI Ø OF BOLT CIRCLE | N. TIRANTI BOLTS | Ø TIRANTI Ø BOLT | Ø FORI Ø HOLES | RF | RJ |
| | | | | | | | | | | |
| 1" | 50,8 | R 16 | | | 88,9 | 4 | 5/8 | 17,5 | 105 | 120 |
| 1 1/4" | 60,3 | R 18 | | | 98,4 | 4 | 5/8 | 17,5 | 105 | 120 |
| 1 1/2" | 68,3 | R 20 | | | 114,3 | 4 | 3/4 | 22,5 | 110 | 130 |
| 2" | 82,5 | R 23 | | | 127,0 | 8 | 5/8 | 17,5 | 105 | 120 |
| 2 1/2" | 101,6 | R 26 | | | 149,2 | 8 | 3/4 | 22,5 | 110 | 130 |
| 3" | 123,8 | R 31 | | | 168,3 | 8 | 3/4 | 22,5 | 110 | 130 |
| 4" | 149,2 | R 37 | | | 200,0 | 8 | 3/4 | 22,5 | 110 | 130 |
| 5" | 181,0 | R 41 | | | 234,9 | 8 | 3/4 | 22,5 | 110 | 140 |
| 6" | 211,1 | R 45 | | | 269,9 | 12 | 3/4 | 22,5 | 110 | 140 |
| 8" | 269,9 | R 49 | | | 330,2 | 12 | 7/8 | 25,5 | 115 | 155 |
| 10" | 323,8 | R 53 | | | 387,3 | 16 | 1 | 28,5 | 140 | 165 |
| 12" | 381,0 | R 57 | | | 450,8 | 16 | 1 1/8 | 32,0 | 140 | 180 |
| 14" | 419,1 | R 61 | | | 514,3 | 20 | 1 1/8 | 32,0 | 155 | 180 |
| 16" | 469,9 | R 65 | | | 571,5 | 20 | 1 1/4 | 35,0 | 165 | 205 |
| 18" | 533,4 | R 69 | | | 628,6 | 24 | 1 1/4 | 35,0 | 165 | 205 |
| 20" | 584,2 | R 73 | | | 685,8 | 24 | 1 1/4 | 35,0 | 180 | 205 |
| 24" | 692,1 | R 77 | | | 812,8 | 24 | 1 1/2 | 41,5 | 190 | 230 |

Non definito dalla
ASME B.16.36
Not defined by
ASME B.16.36